



KC500 **Operation manual**



Keii 科易光电

Symbols Used

	This mark denotes issues that may affect the IR camera's operation.
	This mark denotes additional topics that complement the basic operation procedures.
	This mark denotes complement material or operation procedures.

Trademark Acknowledgments

- KEII is trademarks of KEII Inc.
- Other names and products not mentioned above may be registered trademarks of trademarks of their respective companies.

Copyright©2003-2010 KEII Inc. All rights reserved.

Read This First	Introduction of safety precautions and warnings when using the IR camera.
Component Guide Preparing the IR Camera	Introduction of IR camera components and batteries charging and loading.
User Guide	Describing how to work with the IR camera, including each analysis tools and settings
Troubleshooting	Describing how to solve problems
Appendix	Describing how to maintain the IR camera and introduce related materials' emissivity
Specification	Describing the specification of KC500 You must read this section before connecting your camera to a computer.

Read This First	5
Component Guide	11
Front View.....	11
Back / Bottom View.....	12
Side View.....	12
Preparing the IR Camera	14
Charging the Battery Pack.....	14
Installing the Battery Pack.....	16
Power On / Off.....	17
Menu System.....	18
Setting Date / Time.....	19
Checking Information on LCD Monitor.....	20
IR Camera Adjustment.....	21
User Guide	24
File ---- Open Image & Save Image.....	24
File ---- Text Comment.....	26
File ---- Voice Comment.....	27
File ---- Rec Video & Play Video.....	28
Analysis.....	30
Setting ---- Device.....	33
Setting ---- IR Parameter.....	34
Setting ---- Alarm.....	35
Setting ---- Display.....	37
Setting ---- Other.....	39
System.....	40
System ---- Storage.....	41
System ---- Image.....	42
Laser Pointer & Freeze Key.....	43
Download IR Image to PC.....	44

Troubleshooting	45
Appendix	46
Care & Maintenance.....	46
Emissivity Table.....	47
Specification	52
After Sales Service & Statement	55
Remarks.....	57
Complement.....	59

Test Shots

Before you try to shoot important subjects, we highly recommend that you shoot several trial images to confirm that you are able to operate the IR camera correctly.

Please note that KEII, its subsidiaries and affiliates, and its distributors are not liable for any consequential damages arising from any malfunction of an IR camera or accessory, including CompactFlash™ cards, which results in the failure of an image to be recorded or to be recorded in a format that is machine readable.

Warning Against Copyright Infringement



Safety Precautions

Before using the camera, please ensure that you read and understand the safety precautions described below. Always ensure that the IR camera is operated correctly.

The safety precautions noted on the following pages are intended to instruct you in the safe and correct operation of the IR camera and its accessories to prevent injuries or damage to yourself, other persons and equipment.



Warnings

Read on to learn about using IR camera properly.

- **Avoid damaging eyesight.**

Warning: Do not trigger the laser pointer in human or animal eyes. Exposure to the laser produced by the laser pointer may damage eyesight.

- **Do not disassemble.**

Do not attempt to disassemble or alter any part of the equipment that is not expressly described in this guide.

- **Stop operating immediately if it emits smoke or noxious fumes.**

Failure to do so may result in fire or electrical shock. Immediately turn the power off, and remove the battery or unplug the power cord from the power outlet. Confirm that smoke and fume emissions have ceased.

- **Stop operating immediately if it is dropped or the casing is damaged.**

Failure to do so may result in fire or electrical shock. Immediately turn the power off, and remove the battery or unplug the power cord from the power outlet.

- **Do not use substances containing alcohol, benzene, thinners or other flammable substances to clean or main the IR camera.**

The use of these substances may lead to fire.

- **Remove the power cord on a regular periodic basis and wipe away the dust and dirt that collects on the plug, the exterior of the power outlet and the surrounding area.**

In dust, humid or greasy environments, the dust that collects around the plug over long periods of time may become saturated with humidity and short-circuit, leading to fire.

- **Do not handle the power cord if your hands are wet.**

Handling it with wet hands may lead to electrical shock. When unplugging the cord, ensure that you hold the solid portion of the plug. Pulling on the flexible portion of the cord may damage or expose the wire and insulation, creating the potential for fires and electrical shocks.

- **Do not cut, alter or place heavy items on the power adapter cord.**

Any of these actions may cause an electrical short circuit, which may lead to fire or electrical shock.

- **Use only the recommended power accessories.**

Use of power sources not expressly recommended for this IR camera may lead to overheating, distortion of the IR camera, fire, electrical shock or other hazards.

- **Do not place the batteries near a heat source or expose them to direct flame or heat.**

Neither should you immerse them in water. Such exposure may damage the batteries and lead to the leakage of corrosive liquids, fire, electrical shock, explosion or serious injury.

- **Do not attempt to disassemble, alter or apply heat to the batteries.**

This is serious risk of injury due to an explosion. Immediately flush with water any area of the body, including the eyes and mouth, or clothing, that comes into contact with the inner contents of a battery. If the eyes or mouth contact these substances, immediately flush with water and seek medical assistance.

- **Avoid dropping or subjecting the batteries to severe impacts that could damage the casings.**

It could lead to leakage and injury.

- **Do not short-circuit the battery terminals with metallic objects, such as key holders.**

It could lead to overheating, burns and other injuries.

- **Before you discard a battery, cover the terminal with tape or other insulators to prevent direct contact with other objects.**

Contact with the metallic components of other materials in waste containers may lead to fire or explosions. Discard the batteries in

specialized waste facilities if available in your area.

- **Use only recommended batteries and accessories.**
Use of batteries not expressly recommended for this equipment may cause explosions or leaks, resulting in fire, injury and damage to the surroundings.

- **Disconnect the compact power adapter from both the IR camera and power outlet after recharging and when the IR camera is not in use to avoid fires and other hazards.**
Continuous use over a long period of time may cause the unit to overheat and distort, resulting in fire.

- **Do not use the battery charger or compact power adapter if the cable or plug is damaged, or if the plug is not fully inserted into the power outlet.**
The battery charger varies according to region.

- **Exercise due caution when screwing on the separately sold tele-lens, close-up lens.**
If you loosen, fall off and shatter, the glass shards may cause an injury.

- **If your camera is used for prolong periods, the IR camera body may become warm.**
Please take care when operating the IR camera for an extended period as your hands may experience a burning sensation.



Prevent Malfunction

Read on to learn about preventing malfunction of IR camera

- **Avoid Damaging the Detector of the IR Camera**

Warning: Do not aim the IR camera directly into the sun or at other intense heat source which could damage the detector of the IR camera.

- **Avoid Condensation Related Problems**

Moving the IR camera rapidly between hot and cold temperatures may cause condensation (water droplets) to form on its external and internal surfaces.

You can avoid this by placing the IR camera in the plastic case (bundle) and letting it adjust to temperature changes slowly before removing it from the case.

- **If Condensation Forms Inside the IR Camera**

Stop using the camera immediately if you detect condensation. Continued use may damage the IR camera. Remove the PC card, and battery or a household power source from the IR camera and wait until moisture evaporates completely before resuming use.

- **Extended Storage**

When not using the IR camera for extended periods of time, remove the battery from the IR camera or battery charger and store the IR camera in a safe place. Storing the IR camera for extended periods with battery installed will run down the battery.

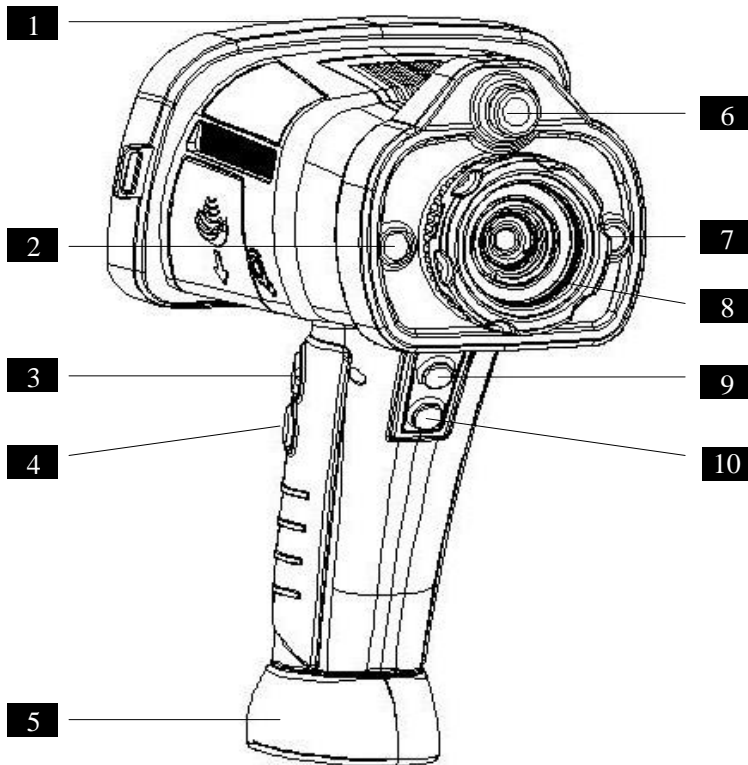

Components

1	External LCD	6	CCD
2	Lamp	7	Laser
3	Shutter	8	Lens
4	Custom key2 (Open Image/Save Image/CCD/Rec Video)	9	Custom key1 (Laser/Text Comment)
5	Battery case	10	Freeze/Live key, Video Rec/Pause (Rec Video configured)

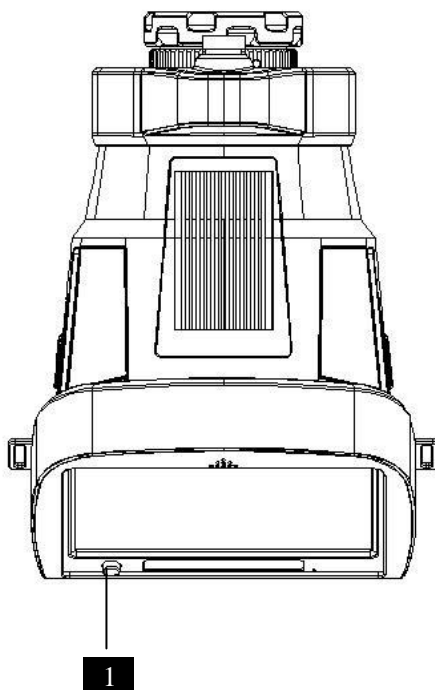

1	Power switch
---	--------------

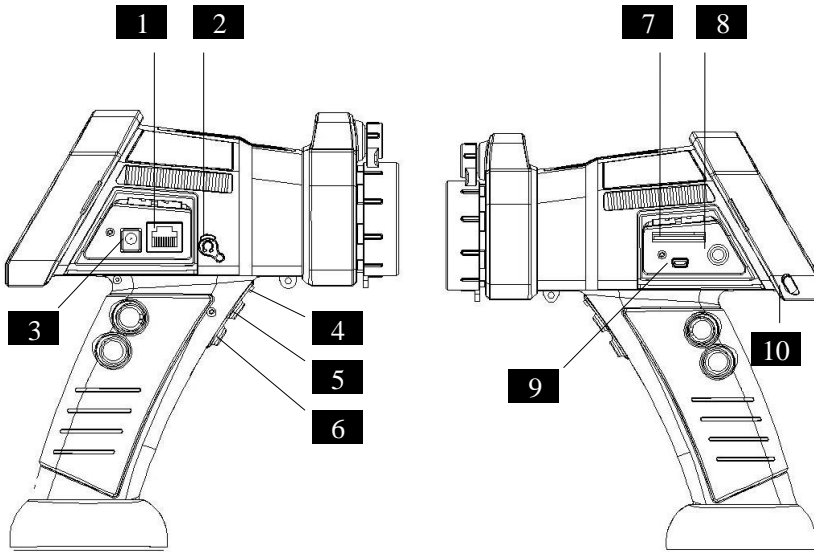

1	RJ45 interface	6	Freeze/Live key, Video Rec/Pause (Rec Video configured)
2	Headset	7	SD card interface
3	External power	8	Video interface
4	Shift key for right-hander and left-hander	9	USB 2.0 interface
5	Custom key1 (Laser/Text Comment)	10	Touching pen

Use the following procedures to charge the battery pack when the low battery icon appears on the display panel.

- 1 Align the edge of the battery pack with the line on the battery, and then slide the battery in the direction of the arrow.

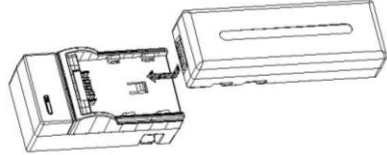

- 2 Attach the power cord to the battery charger and plug the other end into a power outlet.
 - The charge indicator lights while the battery pack is charging and goes off when charging is completed.
 - After charging, unplug the battery charger and remove the battery pack.



- This is a lithium ion battery pack so there is no need to deplete the battery or discharge it before recharging. It can be recharged at any time. Moreover, you are recommended to only charge the battery pack after having discharge it completely in order to prolong battery life.
- Charging times will vary according to the surrounding humidity and battery pack state of charge.

Battery Pack Handling Precautions

- Keep the battery pack and camera terminals clean at all times. Dirty terminals may cause a poor contact between the battery pack and IR camera. Polish the terminals with a tissue or a dry cloth before charging or using the battery pack.
- Do not cover the battery charger with anything, such as a tablecloth, cushion or blanket when it is charging. Heat will build up internally and possibly lead to fire.
- Do not charge batteries other than Battery Pack KC3820 with the supplied equipment. This may cause a malfunction.
- The battery pack continues to discharge a small amount when left in the camera even if it is powered off. This shortens the battery life. Remove the battery pack from the camera when it is not in use.
- Do not allow any metal objects such as key rings to touch the terminals, as it can damage the battery pack. To carry the battery pack, or store it when not used, always place it in the supplied case and store it in a cool and dry place.
- Charged battery packs will discharge naturally. To ensure a full charge, you are advised to charge the battery before using it.
- Since storing a fully charged battery pack for a long period of time (about 1 year) will shorten its lifecycle or affect the performance, you are recommended to use the battery pack in the IR camera until the low battery icon appears and store it at normal temperature (30°C) or lower. If you do not use the battery pack for a long period of time, fully charge and then discharge it in the camera at least once a year before returning it to storage.
- The camera consumes battery when the power is on but no function is being used. To conserve battery, power off the IR camera when it is not in use.
- Although the battery pack's maximum operation range is 0 to 40°C, the optimal range is 10 to 30°C. At low temperatures, performance will temporarily decline, deducting the working time before recharging.
- If the working time of a battery pack diminishes substantially even when the battery pack is fully charged, it should be replaced.

Install Battery Pack KC3820 (supplied) and SD card (supplied) into the camera as follows.

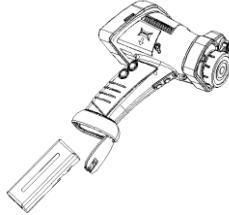

- 1 Check that the power is off and slide the battery cover lock, and the battery cover opens automatically.
- 2 Insert the battery pack.
 - The battery terminal side should face upwards.
 - Insert the battery pack all the way in until the battery lock clicks. To remove the battery pack, push the battery lock.
- 3 Close the battery cover.



- Charge the battery pack before using it for the first time.
- External power (AC) or vehical charger is also available for power supply.
- Remove the battery pack when the camera is not in use.

The power indicator remains lit while the power is on.

Power on the IR camera

- 1 Press and hold the power switch for 3 seconds.
 - The power indicator lights green.

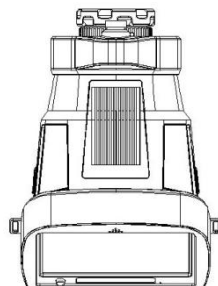

- 2 After a while, a startup image will appear on the screen.







Do not operate the IR camera when it is started up.





Power off the IR camera





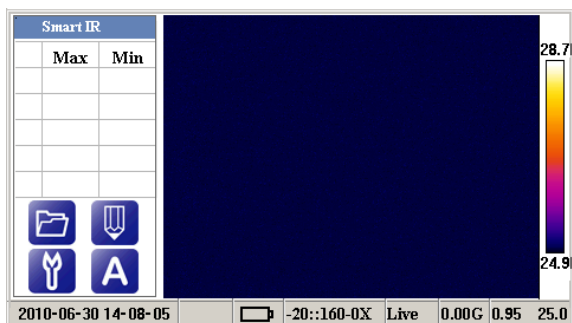



Hold the power switch for 3 seconds.



- The power indicator goes off.

The IR camera is in null mode after being powered on. Shortcut icons -**File**, -**Analysis**, -**Setting** and -**Adjust** are displayed on the lower left corner of the screen. Please enter/exit the menu as follows.





 Do not operate the IR camera for the first 5 seconds in null mode.

- 1 Press // to enter **File**, **Analysis**, **Setting** respectively.
- 2 Press   to select and enter a menu (**File**, **Analysis**, **Setting**, **System** and **Parameter**).
- 3 Press   to select an item and enter the submenu. (Or press the item on the touching screen directly to enter the submenu.)
- 4 Press  to save current settings and exist. Press  to exit without saving changes.



File 	Analysis 	Setting 	System	Parameter
Open Image	Add Point	Device	Storage	Spot
Save Image	Add Line	IR Parameter	Image	Line
Text Comment	Add Box	Alarm	Time/Date	Box
Voice Comment	Isotherm	Display	Key Setup	Isotherm
Rec Video (optional)	Remove All	System	Language	Difference
Play Video (optional)	Para setting	Other	About	Area Setting

Please set Date / Time when the IR camera is powered on for the first time.

1 Press  to enter *Setting*, and press   to select *System*.

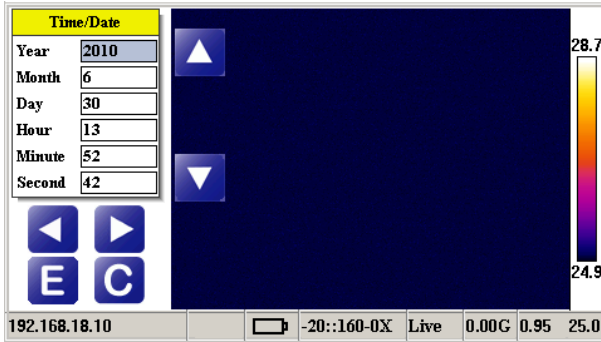
2 Select *Time/Date* and press  to enter the submenu.



3 Select the item which needs to be set or changed, and press   to change values.

4 Press  to save current settings and exist the menu.

The LCD monitor has a view of the actual size of captured images. An information view of the IR camera screen is displayed as follows.

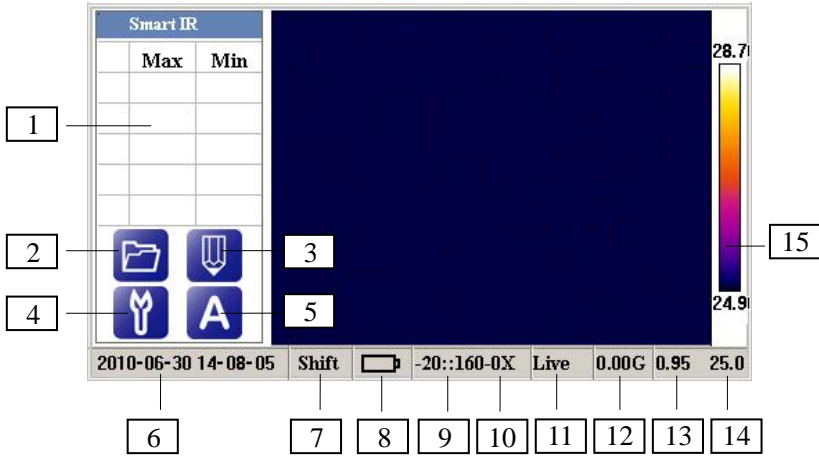

1	Analysis result (≤ 5)	9	Temperature range
2	File menu	10	lens model
3	Analysis menu	11	Freez/Live key (touchable)
4	Setting menu	12	SD card capacity
5	Adjust key	13	Emissvity
6	Data and time/IP address	14	Temperature of chip
7	Key status (touchable)	15	Palette (touchable; available colors: iron, feather, rainbow, grey, etc.)
8	Battery life		

Focus adjustment

1 Aim the IR camera at the subject.

- Do remember to make the subject at the center of the image that is shown on the LCD monitor.

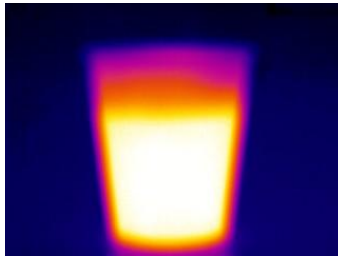

2 Rotate the ring to get a clear image.





Image Zooming

Electronic zoom: 2X/4X/8X

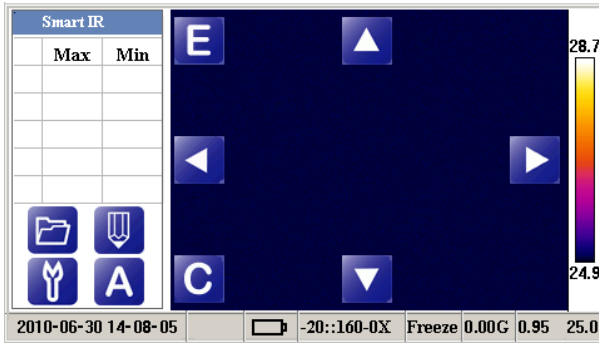
- 1 Click the blank area on the left of the screen, and the IR camera screen is displayed as follows.



- 2 Press  to zoom in the image. Press  to zoom out the image.

 The more the image is zoomed in digitally, the coarser its image quality will be.

Level (Brightness) & Span (Contrast) Adjustment

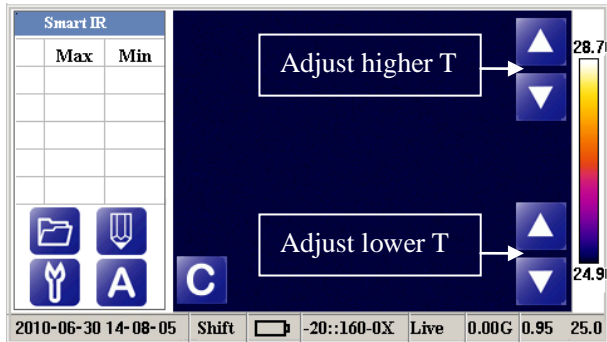

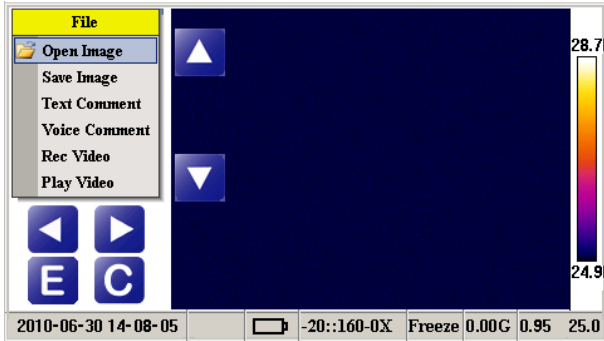

- 1 Press **A** and **▲ ▼** are displayed on the the upper right corner and lower right corner of the screen as shown on the picture.

- 2 Press **▲ ▼** to adjust the higher temperature and lower temperature.



* **Rec Video** and **Play Video** are optional and not in the standard package.

Open Image

- 1 Press  to enter **File**, and select **Open Image** to open image files saved in SD card or build-in memory.
-  Image type and path of saving image can be set in the submenu **Storage**. (Please refer to P41 for more detail.)
- 2 Press **Shift** and saved image files can be displayed in a list or in thumbnail.
- 3 Select the desired image and press  to check the original image.



Save Image

- 1** Aim the IR camera at the subject, rotate the ring and adjust level and span to get the best image, and press **Freeze** to freeze the screen.

- 2** Set the custom key2 to be **Save**, and press this key to save image directly. (Please refer to P40 to check how to set custom key.)







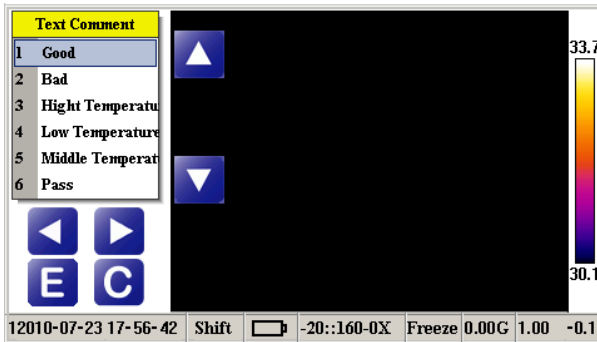

Or press  to enter **File** and select **Save Image**.

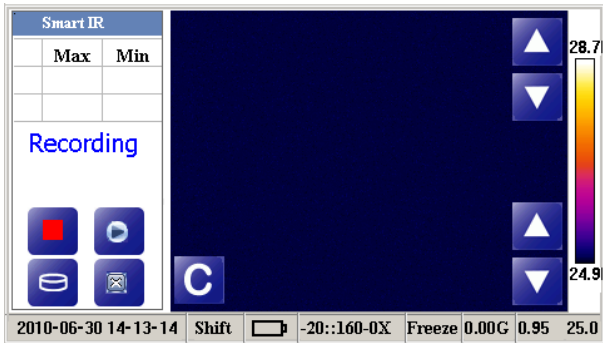



- 1 Open an image, press  to enter *File* and select *Text Comment*.
- 2 Select one text from the predefined text list, and press  to save and exist.









- Only one text can be added to each image. If more than one texts are added to one image, only the last one will be saved.
- Added texts can only be viewed by the IR report software.

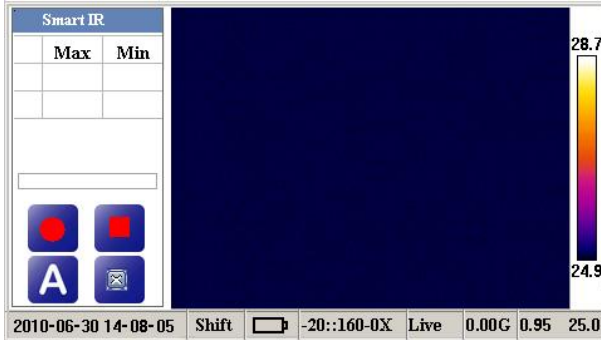





- 1 Open an image, press  to enter *File* and select *Voice Comment*.
- 2 Press  to start/stop recording. Press  to play/stop playing the record.
- 3 Press  save the record, and press  to exist.

- 1 Press  to enter *File*, and select *Rec Video*.
- 2 Press  to start recording a video, press  to pause, and press  again to continue recording.

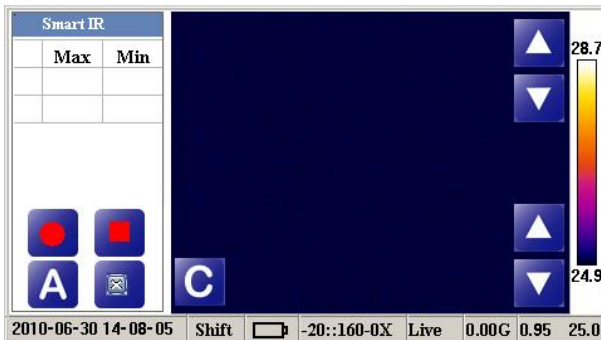

- 3 During recording, press  and   are displayed on the the upper right corner and lower right corner of the screen. Press   to ajust the higher temperature and lower temperature.



- 4 Press  to save the video and exist.
- 5 Press  to enter *File*, and select *Play Video* to open the saved video files.
- 6 Press *Shift* and saved video files can be displayed in a list or in thumbnail.
- 7 Select the desired video and press  to play this video.





How to record a video with custom keys?

- 1 Set custom key2 to be *Rec Video* and custom key1 to be *Text Comment*.
(It can be made only when *Rec Video* is configured. Please refer to P40 to check how to set custom key.)
- 2 Press custom key2 to enter *Rec Video*, and press Video Rec/Pause key (as shown in P11 ) to start/pause/continue recording.
- 3 Press custom key1 to enter *Text Comment* after a video is recorded.
- 4 Press custom key2 again to save the video.

Points, lines, boxes and isotherms can be added to the screen.

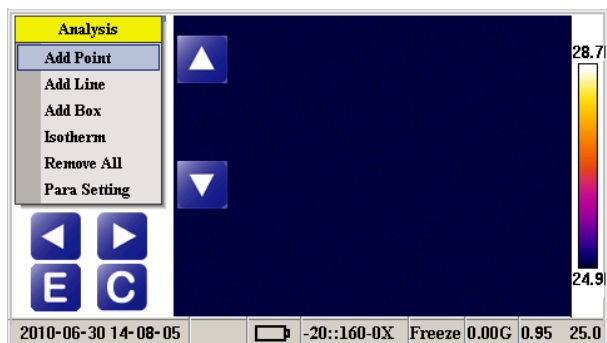
* Ellipse and Polygon functions are optional and not in the standard package.



- 1 Press  to enter *Analysis*.

- 2 Select add point/line/box and the corresponding figure appears.

- 3 Select a figure on the screen, press and drag to move it; press and drag its endpoint to change the size; press other area on the screen to exist editing mode.

- 4 Select a figure and enter *Para Setting* to set its parameter.

Take adding a point for example.

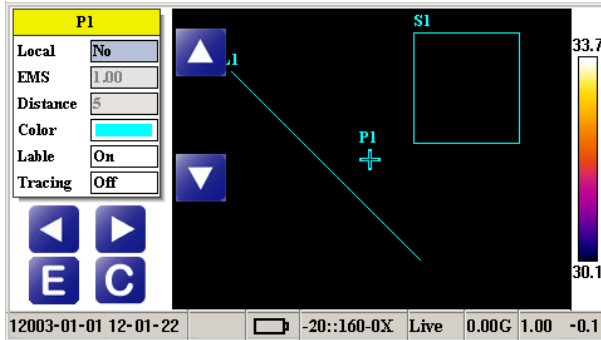

Local	Set parameter only for this point. (Only when it is set to be Yes can <i>EMS</i> and <i>Distance</i> be set.)
EMS	Set emissivity of the object.
Distance	Set a proper distance value between the object and IR camera.
Color	Set the color of this point.
Lable	Select whether to display temperature.
Tracing	Select whether to trace maximum/minimum temperature.

- 5 Click the blank area on the left of the screen and the screen is displayed as shown in the picture of P22, select a figure and press **C** to delete it; select *Remove All* to delete all figures added.



Area Setting



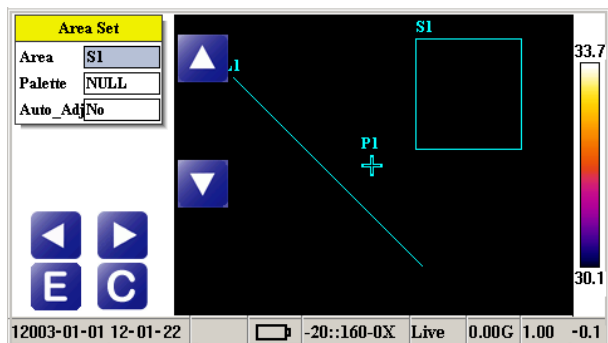

Area Setting is only applied for parameter setting of boxes added.

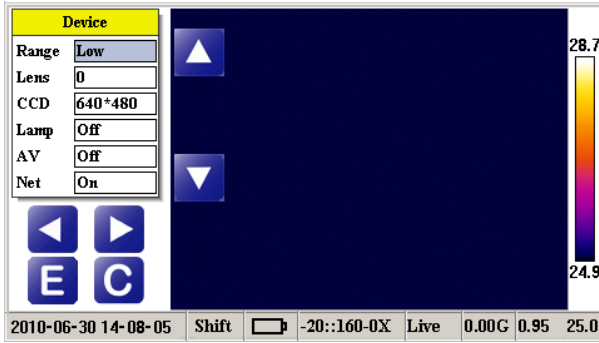

Area	Select the box which needs to be set.
Palette	Set palette inside the box.
Auto_Adj	Select whether to auto-adjust palette.





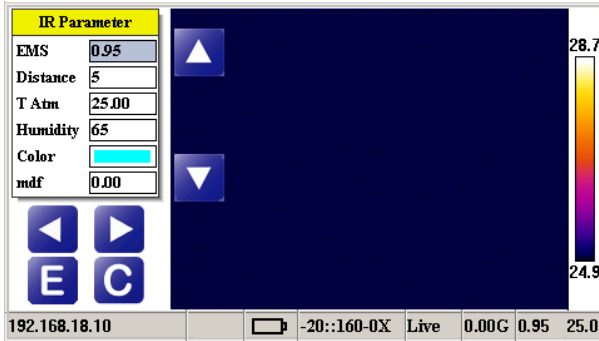

Range	Set temperature range (Low/Middle).
Lens	Set lens model.
CCD	Set pixels of CCD.
Lamp	Lamp on/off
AV	AV on/off
Net	Net on/off

- 1 Press  to enter *Setting*, and select *Device*.
- 2 Select the item which needs to be set or changed, and press   to change values.
- 3 Press  to save current settings and exist the menu.

 If *Network* is set to be *On*, the IR camera needs to be restarted.



EMS	<p>Set emissivity of the object as a whole.</p> <ul style="list-style-type: none"> ● Emissivity varies from one object to another. Please ensure the correct emissivity is set before measuring, since it has the greatest impact on temperature measuring. ● Under this submenu, press Shift and then press E, emissivity of common materials is displayed and can be selected.
Distance	Set a proper distance value between the object and IR camera.
T atm	Set the ambient temperature.
Humidity	Set the ambient humidity.
Color	Set a color for default analysis tools.
mdf	Set the value for modifying.

- 1 Press  to enter *Setting*, and select *IR Parameter*.
- 2 Select the item which needs to be set or changed, and press   to change values.
- 3 Press  to save current settings and exist the menu.

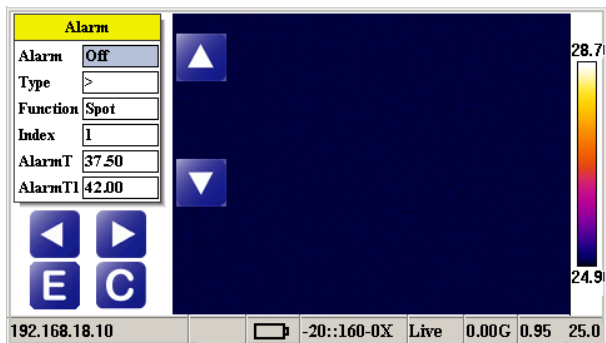

Alarm	Alarm on/off
Type	Set alarm condition.
Function	Set analysis tool for alarm.
Index	Set the number of analysis tool for alarm.
Alarm T	Set alarm temperature.
Alarm T1	Set another alarm temperature. (It needs to be set only when <i>Type</i> is set to be <i>between</i> .)

For example:

An alarm is set when the temperature of Spot 1 is higher than 37.5°C.

1 Press  to enter *Setting*, and select *Alarm*.

2 Select the item and press   to change values as follows.

Alarm: On
Type: >
Function: Spot
Index: 1
Alarm T: 37.5

- 3 Press **E** to save current settings and exist the menu.



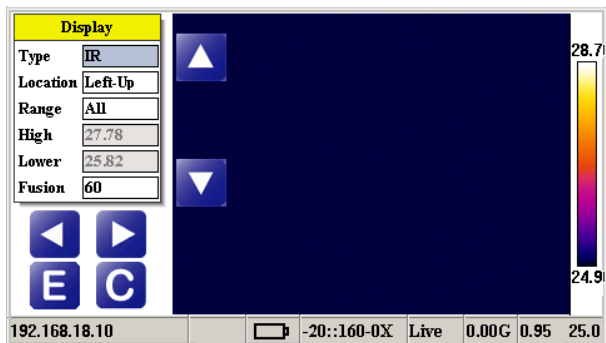

 Sound alarm (for headset only) will stop automatically after 5 seconds, and it will re-open after 30 seconds.



Type	Set the type of image. (IR/ CCD/ Fusion/ CCD&IR/ IR&CCD).
Location	When <i>Type</i> is set to be <i>CCD&IR</i> or <i>IR&CCD</i> , set location of IR image or CCD image. (Left-Up/Right-Up/Right-Down/Left-Down).
Range	Set range (IR/S1/S2/...).
FX	When <i>Type</i> is set to be <i>Fusion</i> , adjust abscissa for fusion.
FY	When <i>Type</i> is set to be <i>Fusion</i> , adjust ordinate for fusion.
Fusion	When <i>Type</i> is set to be <i>Fusion</i> , adjust transperance for fusion.



- Only when *Type* is set to be *Fusion* can *FX*, *FY* and *Fusion* be set to get a better fusion image.
- Value of *Fusion* ranges from 0 to 127. When it is 0, IR image is displayed. When it is 127, CCD image is displayed.

- 1 Press  to enter *Setting*, and select *Display*.
- 2 Select the item which needs to be set or changed, and press   to change values.
- 3 Press  to save current settings and exist the menu.





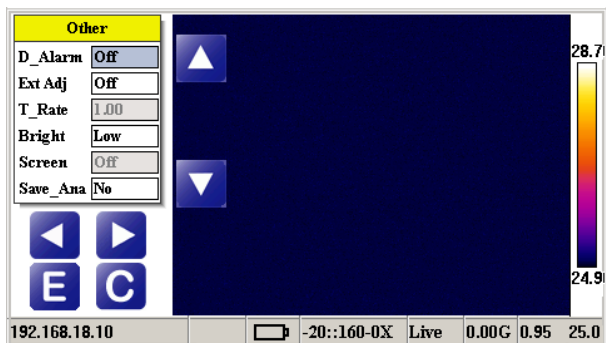

How to get IR and CCD images displayed together at the same time?

- 1 Set *Type* to be *Fusion*.
- 2 Add a box on the screen, and set *Range* to be the box added (e.g. S1).
- 3 Adjust value of *Fusion* from *0* to a proper one, with which a better fusion image is displayed.



D_Alarm	Dew point alarm on/off
Ext Adj	External adjustment on/off
T_rate	Set transmittance rate.
Bright	Set brightness (Low/Middle/High).
Screen	Screen Saver on/off
Save_Ana	Save Analysis on/off

- 1 Press  to enter *Setting*, and select *Other*.
- 2 Select the item which needs to be set or changed, and press   to change values.
- 3 Press  to save current settings and exist the menu.



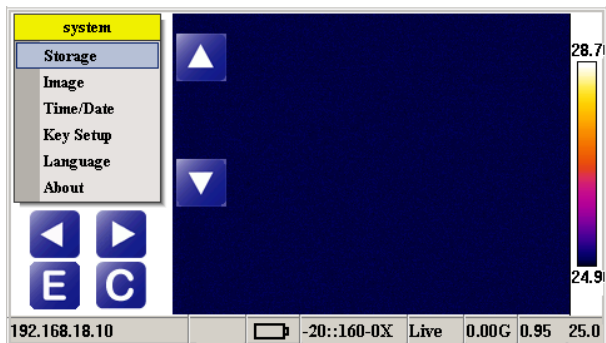

- Set *Ext Adj* to be *On*, and press *Shutter* (refer to P11 ) facing a uniform plane. In this way, external adjustment is finished.
- Set *Save_Ana* to be *Yes*, and analysis tools added to images will be saved together with images; otherwise, analysis tools added will not be saved.

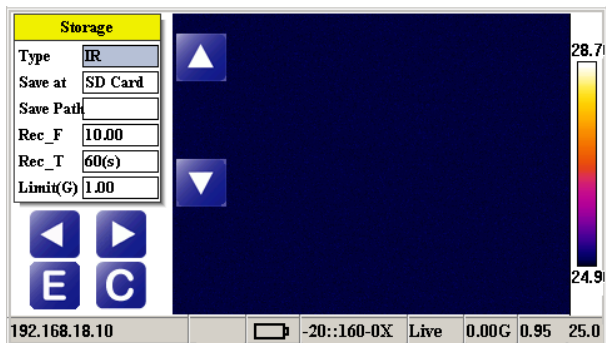

Storage	Set save type, save path, video frame, etc.
Image	Set palette, temperature range, etc.
Time/Date	Set date and time.
Key Setup	Set custom keys. <ul style="list-style-type: none"> Two custom keys (refer to P11 4 9) can be set.
Language	Set language of the menu.
About	View product information.



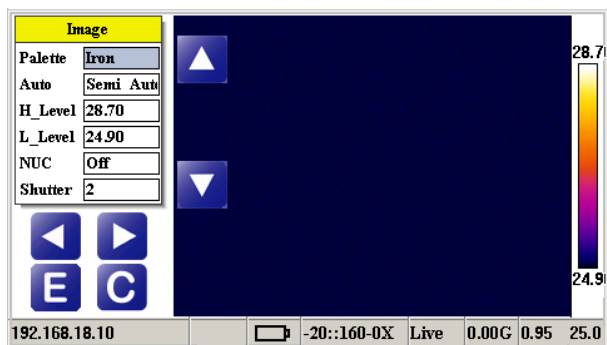

Type	Set save type (IR/CCD/both).
Save at	Set save position (SD card/Memory)
Save Path	Set directory name.
Rec_F	Set frame rate for video recording.
Rec_T	Set video recording time (seconds).
Limit (G)	Set upper limit for video recording memory.

- 1 Enter *System*, and select *Storage*.
- 2 Select the item which needs to be set or changed, and press   to change values.
- 3 Press  to save current settings and exist the menu.



Palette	Select palette.
Auto	Set way of adjust. (Auto/SemiAuto/Manual)
H_Level	Set upper limit of temperature range.
L_Level	Set lower limit of temperature range.
NUC	NUC on/off
Shutter	Set interval of auto shutter (second).

1 Enter *System*, and select *Image*.

2 Select the item which needs to be set or changed, and press   to change values.

3 Press  to save current settings and exist the menu.

 When *Auto* is set to be *Auto*, *H_Level* and *L_Level* cannot be set.

Turn on/off Laser Pointer

Set custom key1 to be **Laser**, and press the key to turn on/off the laser pointer. (Please refer to P40 to check how to set custom key.)

- ⓘ Do not trigger the laser pointer in human or animal eyes. Exposure to the laser produced by the laser pointer may damage eyesight.

Image Freeze Key

Press **Freeze** to switch between Freeze and Live. (Or press **Freeze/Live**, as shown in P20 11, on the touching screen directly.)

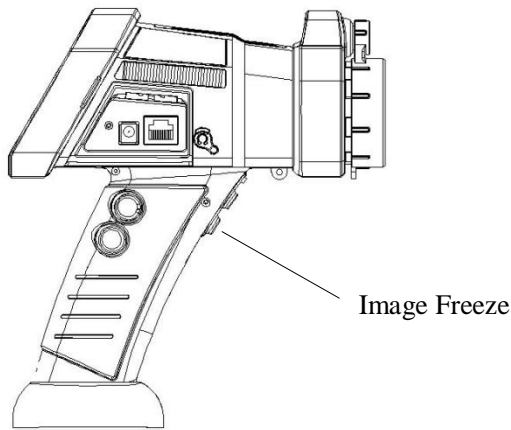

You can download images taken with the IR camera to a computer directly from the SD card or by USB cable.

Download from SD card

- 1 Eject the SD card from the IR camera

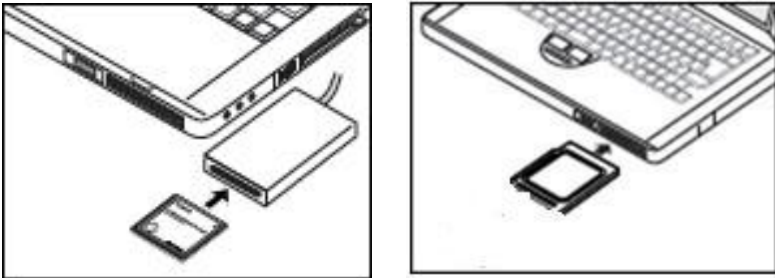

- 2 Insert SD card into the SD card reader connected to a computer
- 3 Copy images from the card into a folder of your choice on the hard disk.

Problem	Cause	Solution
Camera will not operate.	Power may be off.	<ul style="list-style-type: none"> • Turn on the camera. See Turning the Power On/Off.
	Insufficient battery voltage	<ul style="list-style-type: none"> • Fully charge the battery.
	Poor contact between camera and battery terminals	<ul style="list-style-type: none"> • Wipe the terminals with a clean and dry cloth.
Camera will not record.	SD card may be full.	<ul style="list-style-type: none"> • Insert a new SD card. • If possible, download the images to a computer and erase them from the SD card to make some space.
	SD card may not be recognized.	<ul style="list-style-type: none"> • Format SD card to FAT32. • If reformatting doesn't work, the SD card logic circuits may have been damaged. Contact Local Service Department.
Battery pack will consume quickly.	Battery pack may have been in disuse for one year or more after being fully charged.	<ul style="list-style-type: none"> • Replace the battery pack with a new one.
	Battery life may exceed.	<ul style="list-style-type: none"> • Replace the battery pack with a new one.
Battery pack will not charge.	Poor contact between battery pack and battery charger.	<ul style="list-style-type: none"> • Clean the battery terminals with a clean cloth. • Connect the power cord to the battery charger and insert its plug firmly into the power outlet.
	Battery life may exceed.	<ul style="list-style-type: none"> • Replace the battery pack with a new one.

Use the following procedures to clean the camera body, lens, LCD monitor and other parts.

Camera body	Wipe the body clean with soft cloth or eyeglass lens wiper.
Lens	<p>First use a lens blower brush to remove dust and dirt, and then remove any remaining dirt by wiping the lens lightly with soft cloth.</p> <ul style="list-style-type: none"> • Never use synthetic cleaners on the camera body or lens.
LCD monitor	<p>Use a lens blower brush to remove dust and dirt. If necessary, gently wipe the LCD monitor with soft cloth or an eyeglass lens wiper to remove stubborn dirt.</p> <ul style="list-style-type: none"> • Never rub or press forcefully on the LCD monitor. These actions may damage it or lead to other problems.

 Never use thinners, benzene, synthetic cleaners or water to clean the camera. These substances may distort or damage the equipment.

Material	Temperature (°C)	Emissivity
Metals		
Aluminum		
Highly polished	100	0.09
Commercial sheet	100	0.09
Lightly oxidized	25~600	0.10~0.20
Heavily oxidized	25~600	0.30~0.40
Brass		
Brass lens, highly polished	28	0.03
Oxidized	200~600	0.61~0.59
Chromium		
Polished	40~1090	0.08~0.36
Copper		
Copper lens	100	0.05
Highly oxidized	25	0.078
Cuprous oxide	800~1100	0.66~0.54
Liquid copper	1080~1280	0.16~0.13
Gold		
Gold lens	230~630	0.02
Iron		
Cast, polished	200	0.21
Cast, machined	20	0.44
Rusty surface	20	0.69
Cast (oxidized at 600°C)	198~600	0.64~0.78
Electrolytic, oxidized	125~520	0.78~0.82
Oxidized	500~1200	0.85~0.89

Material	Temperature (°C)	Emissivity
Metals		
Iron plate	925~1120	0.87~0.95
Cast, highly oxidized	25	0.80
Thawy surface	22	0.94
Cast, thawy	1300~1400	0.29
Liquid	1515~1680	0.42~0.45
Steel		
Steel (oxidized at 600°C)		
Oxidized	100	0.74
Mild steel, thawy	1600~1800	0.28
Liquid	1500~1650	0.42~0.53
Lead		
Pure lead (unoxidized)	125~225	0.06~0.08
Lightly oxidized	25~300	0.20~0.45
Magnesium		
Magnesium oxidized	275~825	0.55~0.20
Mercury		
Mercury	0~100	0.09~0.12
Nickel		
Electroplated, polished	25	0.05
Electroplated, unpolished	20	0.01
Filament	185~1010	0.09~0.19
Nickel plate (oxidized)	198~600	0.37~0.48
Oxidized	650~1255	0.59~0.86
Nickel alloys		

Material	Temperature (°C)	Emissivity
Metals		
Nichrome, wire (heat resistant)	50~1000	0.65~0.79
Nichrome	50~1040	0.64~0.76
Nichrome (heat resistant)	50~500	0.95~0.98
Silver		
Polished	100	0.05
Stainless steel		
18-8	25	0.16
304 (8Cr, 18Ni)	215~490	0.44~0.36
310 (25Cr, 20Ni)	215~520	0.90~0.97
Tin		
Commercial tin plate	100	0.07
Zinc		
Oxidized at 400°C	400	0.01
Iron plate, galvanized, bright	28	0.23
Gray oxidized	25	0.28

Material	Temperature (°C)	Emissivity
Non-metals		
Brick	1100	0.75
Firebrick	1100	0.75
Graphite (lampblack)	96~225	0.95
Porcelain (white)	18	0.90
Asphalt	0~200	0.85
Glass	23	0.94
Glass, heat resistant	200~540	0.85~0.95
Wall powder	20	0.90
Oak	20	0.90
Carbon sheet		0.85
Insulation sheet		0.91~0.94
Metal sheet		0.88~0.90
Glass pipe		0.90
Loop		0.87
Porcelain goods		0.90
Porcelain flower pattern		0.83~0.95
Solid material		0.80~0.93
Capacitor		
Revolving type		0.30~0.34
Porcelain		0.90
Film		0.90~0.93
Talc		0.94~0.95
Talc, flume type		0.90~0.93
Glass		0.91~0.92
Semiconductor		
Transistor (plastic)		0.80~0.90
Transistor (metal)		0.30~0.40

Model: KC500	
Imaging Performance	
Field of view	32 °×24 ° 0.1m
Spatial resolution (IFOV)	1.45 mrad
Thermal sensitivity	0.05 °C at 30 °C
Image frequency	50/60 Hz non-interlaced
Focus	Manual
Electronic zoom function	2X, 4X, 8X
Detector type	Focal Plane Array (FPA), uncooled microbolometer 384 × 288pixels
Spectral range	7.5-14 μm
Digital image enhancement	Normal and enhanced
Built-in digital video	1280 × 1024 pixels, full color
Image Presentation	
Video output	Composite video
External display	4.3" LCD with touch screen
Palettes	6 standard palettes/independent palette for box areas
Gemi-vision	IR image overlap with visible light image
Measurement	
Temperature range	-20 °C to +350 °C , up to 1500 °C (optional)
Accuracy	±2 °C , ±2% of reading
Point	No limitation, automatic placement and reading of max. & min. average temperature within area
Line profile	No limitation

Area	6 areas
Isotherm	2 options
Emissivity correction	Variable from 0.1 to 1.0, or select from listings in pre-defined materials list
Environmental Specification	
Operating temperature range	-15 °C to +50 °C (5°F to +122°F)
Storage temperature range	-40 °C to +70 °C (-40°F to +122°F)
Humidity	Operating and storage 10% to 95%, non-condensing
Encapsulation	IP 54, IEC529
Shock	Operational: 25G, IEC 68-2-29
Vibration	Operational: 2.5G, IEC 68-2-6
Image Storage	
Type	Build-in flash memory (1G), removable SD-card, up to 16G, optional, 16 bit measurement data storage into SD-card
File formats-Thermal	Standard JPEG and IMA, 16 bit measurement data included
File formats-Visual	Standard JPEG (including movable marker) linked with corresponding thermal image
Voice annotation of images	60 sec of digital voice “clip” stored together with the image Bluetooth wireless headset (optional)
Text annotation of images	Predefined text selected and stored together with the image
Optional Lens	
Field of view	8 °×6 °, 16 °×12 °, 48 °×36 °
System Status Indicator	
LCD display	Shows status of battery and storage media

	Indication of power, communication and storage modes
Laser Pointer	
Classification	Class 2
Type	Semiconductor AlGaInP Diode Laser: 1 mW/635 nm red
Battery System	
Type	Li-Ion, rechargeable, field replaceable
Operating time	3 hours continuous operation
Charging system	In camera (AC adapter or 12 V from car) or 2 bay intelligent charger (cable with Std plug; optional)
Power saving	Automatic shutdown and sleep mode (user selectable)
Physical Characteristics	
Weight	≤1 kg
Size(L×W×H)	190mm×142mm×212.5mm
Interface	
RJ45 (optional)	16 bit fully radiometric IR-video transfer to PC
USB	Image (thermal and visual), measurement, voice and text transfer to PC
Video Storage	
Type	Recording of 16 bit fully radiometric IR-video to SD-card (optional)

After Sales Service & Statement

After Sales Service

We hereby giving guarantee that all material/equipment to be furnished new and unused and shall be first class in every particular case and shall be free from defects. We further warrants that the goods will be new, merchantable of the most suitable grade and fit for their intended purposes.

The Instruments will be guaranteed against manufacturer defects for 12 months from the date of receipt.

This product is warranted against defective materials and workmanship for a period of one (1) year from the delivery date of the original purchase, provided such products have been under normal storage, use and service and in accordance with Keii's instruction. Keii will repair or replace, at its option, the defective product with reasonable charge subject to misuse, neglect, accident or abnormal conditions of operation.

Statement

Guangzhou Keii Electro Optics Technology Co., Ltd follows the policy of development. Therefore, Keii has the right to modify and develop the hardware and software of this product, and this operation manual without prior notice.



Add: F1101A, No.11,Caipin Rd,
Science City, Guangzhou, China

PC: 510663

Website: www.keii.com.cn

E-mail: keii@keii.com.cn